

**Gasoline**  
**5.0 kW 60 Hz**  
**5.0 kW 50 Hz**



## Portable GenSet

- Onan® Elite™ 14 hp Overhead Valve Engine
- Full-Featured Control Panel
- Electric Start
- Low Oil Pressure Shutdown with Indicator Light
- 9-gal, 11-hr Fuel Tank
- Idlematic with Switch

## Models and Ratings

| <u>Model</u>     | <u>Starter</u>      | <u>Hz</u> | <u>Voltage</u> | <u>Max Watts</u> | <u>Max Amps</u> | <u>Rated Watts</u> | <u>Rated Amps</u> | <u>AC Receptacles</u>                                                     |
|------------------|---------------------|-----------|----------------|------------------|-----------------|--------------------|-------------------|---------------------------------------------------------------------------|
| 5.0 EGHAB/38018* | Recoil              | 60        | 120/240        | 5000             | 41.6/20.8       | 5000               | 41.6/20.8         | (1) Duplex 120V/15A GFI<br>(1) Duplex 120V/30A TL<br>(1) 120/240V/20A TL  |
| 5.0 EGHEB/38018* | Electric/<br>Recoil | 60        | 120/240        | 5000             | 41.6/20.8       | 5000               | 41.6/20.8         | (1) Duplex 120V/15A GFI<br>(1) Duplex 120V/30A TL<br>(1) 120V/240V/20A TL |
| 5.0 EGHEM/34879  | Electric/<br>Recoil | 50        | 110/220        | 5000             | 45.4/22.7       | 4500               | 40.9/20.4         | International**                                                           |

\*CSA-approved.

\*\* A variety of international receptacles are available upon request.

Ratings apply to altitudes up to 500 ft (152.4 m), 85° F (29.4° C).

Derating: Power output will decrease 3.5% for each 1000 ft (305 m) above sea level and 1% for each 10°F (5.5° C) increase in ambient temperature about 85° F (29° C).

## Weight, Size and Sound Level

- Dry Weight: electric start, 195 lb (88 kg); recoil start, 186 lb (84 kg)
- Length: 29.2 in (743 mm); Width: 22.5 in (572 mm); Height: 28.0 in (711 mm)
- With Dolly Kit: Length: 48.1 in (1222 mm); Width: 34.0 in (864 mm); Height: 36.25 in (921 mm)
- Sound Levels
  - Idlematic: 67 dB(A) at 7 m, 81 dB(A) at 1 m
  - Full Load, 60 Hz: 79 dB(A) at 7 m, 92 dB(A) at 1 m
  - Full Load, 50 Hz: 75 dB(A) at 7 m, 88 dB(A) at 1 m

## Standard Features

- Onan® Elite™ 14-hp overhead valve engine
- Low oil pressure shutdown
- Electronic ignition
- AC and DC manual reset circuit breakers
- Dual element air cleaner
- Wrap-around protective cradle of 1-in steel tubing
- USDA spark-arresting muffler
- Vibration isolator frame mountings
- Recoil start (electric and recoil start on EGHEB and EGHEM models)
- 9-gal 11-hr fuel tank at rated load
- Solid state automatic voltage regulator
- Full-flow oil filter
- Voltmeter
- Full-power switch

## Receptacles

- 5.0 EGHAB/38018 and 5.0 EGHEB/38018 (CSA-approved) (60 Hz)
  - (1) Duplex 120V/15A GFI (AC) (NEMA 5-15R)
  - (1) 120V/30A Twistlock (AC) (NEMA L5-30R)
  - (1) 120/240V/20A Twistlock (AC) (NEMA L14-20R)
  - (1) 12V/10A 120W (DC)
- 5.0 EGHEM/34879 (Non-CSA-approved) (50 Hz)
  - (1) 12V/10A 120W (DC)
  - International receptacles available upon request
- Simultaneous AC and 12V DC
- Electric start on EGHEB and EGHEM models w/battery tray (battery not included). Recommended: 180 cca minimum @ 40° F, 300 cca @ -20° F
- 12 V DC battery charging with cables

## Accessories

- Two wheel dolly kit - (part #410-1166)
- Twistlock plug 120 V/30 A, NEMA L5-30P (part #323-0862)
- Twistlock plug 120/240 V/20 A, NEMA L14-20P (part #323-0857)

## Engine and Performance Detail

**Design:** 4-cycle gasoline  
**Cylinders:** 1  
**Bore:** 3.31 in (84.2 mm)  
**Stroke:** 2.76 in (70 mm)  
**Displacement:** 23.8 in<sup>3</sup> (390 cm<sup>3</sup>)  
**Power:** 14 bhp max  
**Sound level:** 79 dB(A) (60 Hz sets), 75 dB(A) (50 Hz set) at 7 m and rated load  
**Cylinder liner:** Cast iron  
**Valves:** Overhead valve configuration. Premium valve materials, replaceable guides and seats and intake stem seals.

### Typical fuel consumption

| Gasoline, gph (Lph) | No load | Half load  | Full load  |
|---------------------|---------|------------|------------|
| 60 Hz               | NA      | 0.48 (2.0) | 0.82 (3.4) |
| 50 Hz               | NA      | 0.48 (2.0) | 0.82 (3.4) |

**Lubrication system:** Positive displacement oil pump (full pressure lubrication) with filter  
**Lube oil capacity:** 1.0 qt (0.9 L) with filter  
**Approximate run time:** 10 hr at rated load  
**Fuel tank capacity:** 9 gal (34 L)  
**Starting:** Electric and recoil start on 5000E; recoil start only on 5000  
**Automatic decompression release system**

## Alternator Detail

**Design:** 2-pole AC alternator  
**Exciter System:** Self-excited.  
 Permanent magnet provides instant voltage buildup.  
**Cooling:** Air-cooled

**Voltage Regulator:** Automatic

## GenSet Detail

|                      | No load - full load | Constant load |
|----------------------|---------------------|---------------|
| Voltage regulation   | ±3%                 | ±2%           |
| Frequency regulation | ±4%                 | ±2%           |

# Basic Dimensions

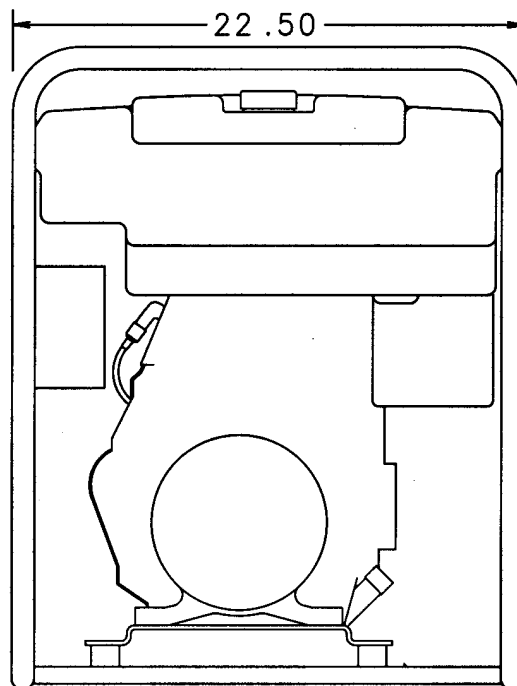
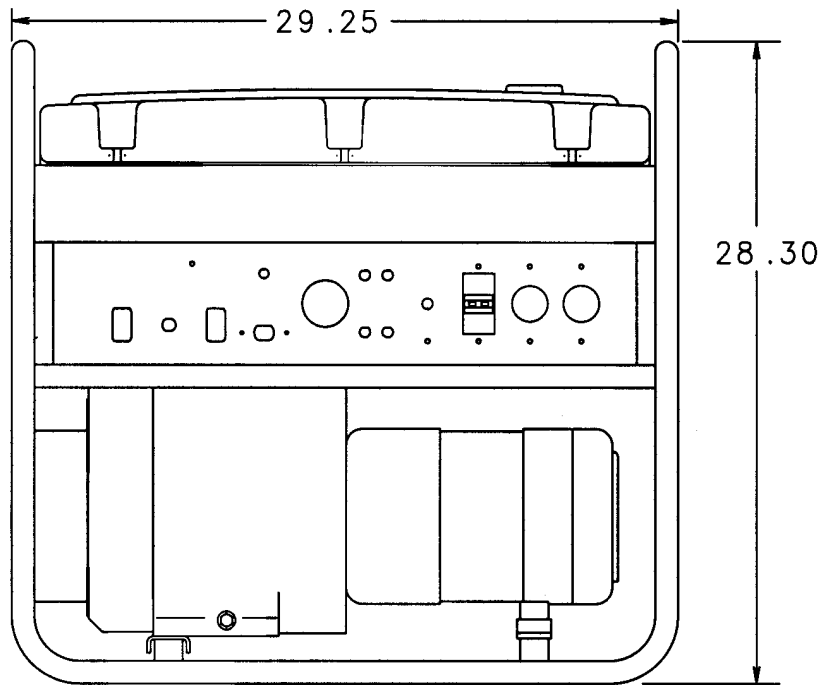

500-2703

This outline drawing is provided for general reference only and is not intended for design or installation. See installation manual and obtain outline drawing 500-2703 for more information (available from your Distributor/Dealer).

---

## Warranty Policy

Onan Pro Series Portable GenSets are backed by Onan's standard three-year limited warranty, with an optional five-year extended warranty. See your local Distributor/Dealer for details.

---

## After Sale Support

### GENUINE ONAN MAINTENANCE PARTS AND PRODUCTS

For your ongoing satisfaction and the dependability of your Onan genset, Onan offers a complete line of replacement and tune-up parts, oil and maintenance chemicals specifically designed for gensets. Easy to find at Onan service and parts dealers coast-to-coast, Onan Green Label™ parts are packaged for correct selection and convenient storage.

### EASY TO LOCATE CERTIFIED ONAN SERVICE AND PARTS DEALERS

Onan has over 400 certified commercial service dealers covering most major metropolitan areas in the U.S. and Canada. To locate Onan service dealers in your area, call 1-800-888-ONAN and request a commercial service and parts dealer directory (F-1060).

---

## Standards and Testing

Tested at extremes of temperature -20°F to +120°F for starting and operation. 60 Hz models (120/240V only) listed by Nationwide Consumer Testing Institute, Inc. per ANSI/EGS-1 and CSA certified per electrical Bulletin 946.

Tested in high humidity conditions.

Tested in salt spray conditions.

Tested in heavy air borne dust conditions.

Field Test Program.

This product meets US. EPA Phase 1 and 1995-1999 California Regulations for utility and lawn and garden equipment engines.

Do not use this genset on a boat. Such use may violate U.S. Coast Guard regulations, and can result in severe personal injury or death from fire, explosion, electrocution, or carbon monoxide poisoning.

---

## Contact your Distributor/Dealer for more information:



To easily locate the nearest Onan Distributor/Dealer, or for more information, contact Onan at 1-800-888-ONAN or 763-574-5000; 1400 73rd Avenue N.E., Minneapolis, MN 55432 U.S.A.; fax 763-574-5298; [www.onan.com](http://www.onan.com).

Onan is a subsidiary of Cummins Engine Company. Onan is a registered trademark of Onan Corporation. Cummins is a registered trademark of Cummins Engine Company.

**WARNING:** Backfeed to utility systems can cause electrocution or property damage. Do not connect to building electrical except through approved device and after building main breaker is opened.